

Advanced quartz-enhanced photoacoustic trace gas sensor for early fire detection

A. A. Kosterev and F. K. Tittel
Rice University

G. Bearman
JPL

Copyright © 2008 SAE International

ABSTRACT

A spectroscopic trace gas sensor using a distributed feedback diode laser at $\lambda=1.53\ \mu\text{m}$ and based on quartz enhanced photoacoustic spectroscopy technique is described. The sensor is capable of quasi-simultaneous quantification of trace ammonia, hydrogen cyanide, and acetylene (NH_3 , HCN , and C_2H_2 , respectively) concentrations at ~ 100 ppbv levels with a 4s integration time. The sensor design, responsivity, noise, and cross-talk characteristics are reported.

INTRODUCTION

Manned space missions require long term, real-time monitoring of the spacecraft atmosphere to alert the crew of potentially dangerous events such as the onset of a fire, overheating of electric wiring insulation, unintended release of chemicals, or malfunctions of the air regeneration system. Requirements for replacing current trace gas sensors intended for space missions include low mass, small footprint, high reliability, and long operating times. Therefore, there is a need to develop new technologies that can best satisfy these criteria [1]. Laser based chemical gas sensors are emerging devices which have the potential to outperform or complement currently used sensors.[2-5]. Diode lasers in the near-IR (NIR) range initially designed for telecommunication applications are guaranteed for continuous operation for >10 years, feature miniature packaging and low weight. For gas sensing applications these light sources must be supplemented with the appropriate absorption sensing technology. For example J. S. Pilgrim et al. reported such a sensor based on a photoacoustic spectroscopy (PAS) approach [6]. In this paper we describe a multi-species trace gas sensor based on quartz enhanced photoacoustic spectroscopy (QEPAS), a spectroscopic technology using unprecedentedly small and light-weight sensing modules [7-20].

The primary motivation for this work was detection of trace gases that can either signal the fire offset or need to be cleaned up after a fire event. From a list of the relevant molecular species we selected the three molecules which have relatively strong and overlapping but resolved NIR absorption bands and hence can be detected using only one distributed feedback diode laser (DFB DL). The selected species are ammonia, hydrogen cyanide, and acetylene (NH_3 , HCN , and C_2H_2 , respectively). All of these molecules have been previously detected individually using QEPAS technology [3]. The list of accessible species can be expanded by using other or additional laser sources.

QEPAS TRACE GAS SENSOR: DESIGN AND PERFORMANCE

QEPAS TECHNOLOGY - A novel approach to photoacoustic detection of trace gases utilizing a quartz tuning fork (QTF) as a sharply resonant acoustic transducer was first reported in 2002 [7]. A QTF is a U-shaped, mass produced quartz crystal intended for use in electronic clocks and watches as a frequency standard. QTFs resonate at $32,768\ (2^{15})$ Hz in clock circuits. A typical design of the QTF based spectrophone (a device detecting optically generated sound waves) and a photograph of its practical implementation are shown in Fig. 1.

SELECTION OF ANALYTIC LINES - The commercial availability of high performance diode lasers in the near-infrared (NIR) spectral region has led to their wide use for gas sensing applications. A DFB DL operating at $\lambda=1.53\ \mu\text{m}$ was used in this work to detect NH_3 , C_2H_2 , and HCN . NIR absorption bands of these molecules overlap and have comparable intensity (see Fig. 2). At the same time, each band consists of narrow individual lines, and it is possible to select lines with minimal or no spectral overlap.

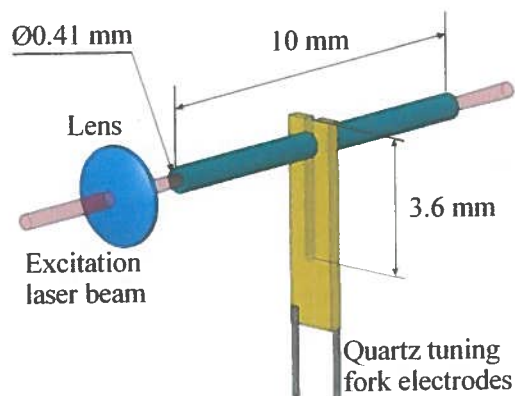

(a)

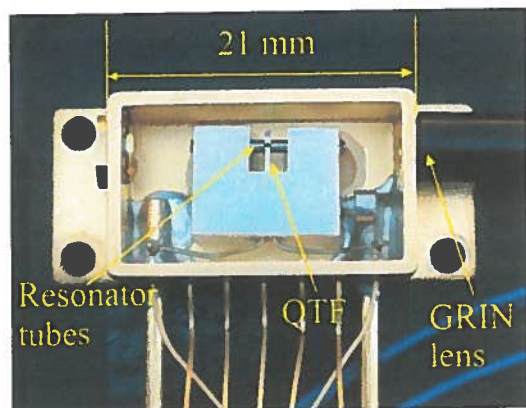

(b)

Figure 1: QTF based spectrophone schematic (a) and its practical implementation (b). The module shown in (b) has two 1/16" tubes to serve as inlet and outlet of gases to be analysed and, when fully assembled, a hermetic top lid. Laser radiation is delivered via a single mode fiber attached to the GRIN lens focusing element.

molecules, NH_3 and C_2H_2 , is known to be independent of the gas humidity.

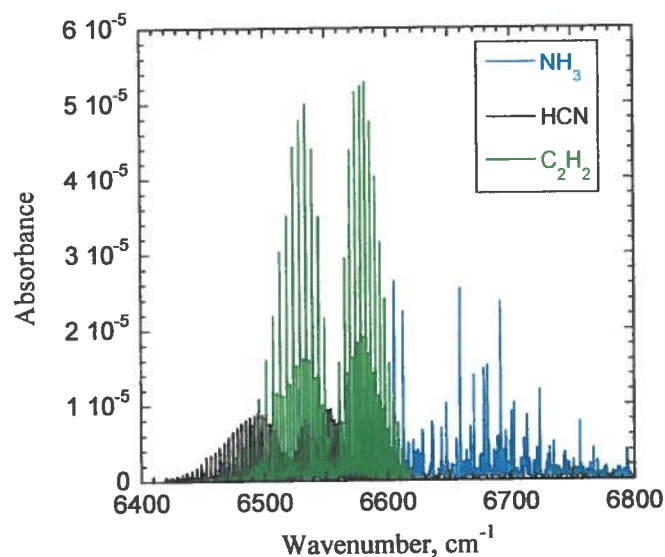

Figure 2: NIR absorption spectra of NH_3 , HCN and C_2H_2 obtained from the Pacific Northwest National Laboratory (PNNL) spectral FTIR database (1 atm, 1 ppmv, 1 m, base 10).

Table 1. Selected absorption lines.

Molecule	Spectral peak, cm^{-1}	Laser T, $^{\circ}\text{C}$	Laser I, mA	Power, mW
NH_3	6528.80	+27.0	489	62
HCN	6536.48	+8.9	456	63
C_2H_2	6523.87	+39.0	500	58

We searched for specific absorption lines satisfying the following selection criteria:

- Fall within the spectral thermal tuning range of a DFB DL, which is typically $\sim 15 \text{ cm}^{-1}$ for a $\Delta T = 40^{\circ}\text{C}$ laser temperature variation.
- Do not overlap with spectral lines of commonly abundant atmospheric gases such as H_2O and CO_2 .
- Exhibit minimum cross-molecular overlap.
- Be one of the strongest lines for each target molecule.

Based on these criteria, the absorption lines listed in Table 1 were selected. The sensor operating pressure was chosen to be 450 Torr. This pressure can be obtained using a compact, low power diaphragm vacuum pump, and can be controlled using inexpensive and miniature mechanical components. At the same time, such a relatively high pressure minimizes the H_2O vapor influence on the photoacoustic response of HCN at 32.8 kHz [16]. QEPAS response of the other two

QEPAS SENSOR CONFIGURATION – A schematic configuration of the multispecies trace gas QEPAS sensor is shown in Fig. 3.

All the elements inside the area outlined by dashed lines are located in a $250 \times 250 \times 100 \text{ mm}$ metal enclosure with an LCD panel and a keypad. This part of the sensor is called Control Electronics Unit, or CEU. The latest CEU version also contains several optical elements: DFB DL coupled to a single mode fiber, 99/1 and 33/33/33 beam splitters (BS1 and BS2, respectively), and three gas-filled reference cells. Each reference cell has a metal housing incorporating both a fiber coupled collimator and a photodiode. The basic operation of similar single-gas QEPAS sensors was described in earlier publications [13]. The main distinction of the current CEU is a commutator (Comm in Fig. 3) that switches signals from the reference photodiodes, and microcontroller software modifications allowing the laser parameters (temperature, current and modulation index) to be cycled through the 3 set points called channels (Ch0 to Ch2).

Thus, one DFB diode laser can sequentially access the lines listed in Table 1, and each time the wavelength is locked to the current absorption line using the appropriate reference cell and a 3f wavelength locking technique. Temperature, pressure, and humidity sensors (not shown in Fig. 3) are connected to the CEU and their readings are logged into the internal CEU flash memory along with the measured QTF signal (in-phase and quadrature), 3f reference photodiode signal, laser power, and laser current. The CEU is capable of both fully autonomous operation and of being remotely controlled by a computer using the RS 232 serial interface.

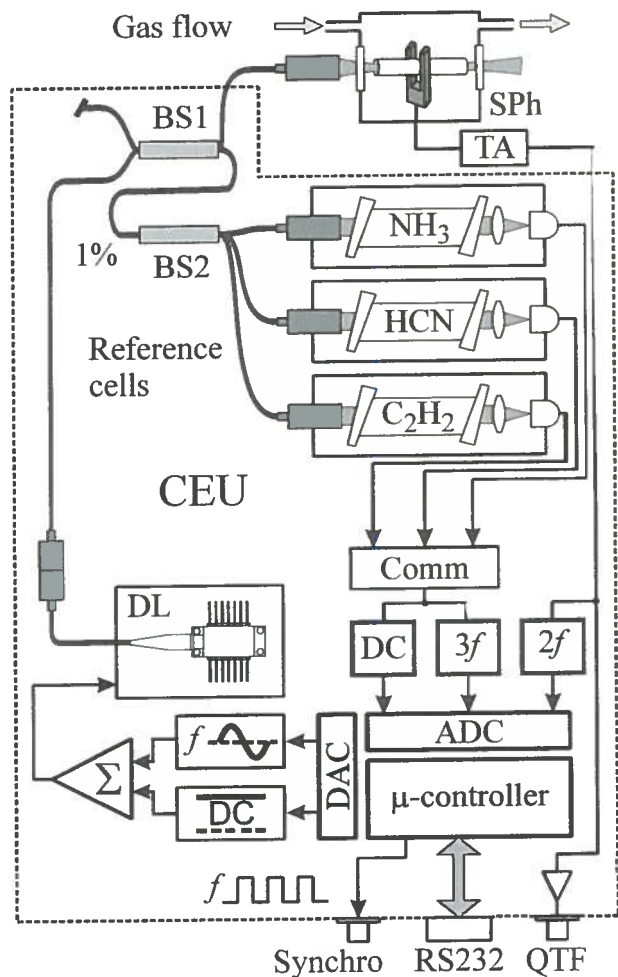

Figure 3: Schematic of the multi-species trace gas QEPAS sensor configuration. CEU – control electronics unit; SPh – spectrophone; TA – transimpedance preamplifier; BS1, BS2 – fiber beam splitters; DL – DFB diode laser; Comm – commutator for the photodiodes of the reference cells.

The detected QTF signal was digitally filtered with 0.785 Hz equivalent noise bandwidth (ENBW), and the digitized result sent to the RS232 interface and an LCD panel every 1s. A second stage filter has an ENBW=0.045Hz with a 10s update rate. Digitization is performed using a 24-bit ADC. Physically, an 1 ADC count (cnt)= 1.85×10^{-9} V RMS at the TA preamplifier

output, or a 1.85×10^{-16} A RMS current generated by the QTF. Thermal noise of the QTF is ~1000 cnt in a 0.785 Hz bandwidth (room temperature, 450 Torr). Hence, the practical dynamic range of the CEU is $2^{23}/1000 \approx 8400$ if only the 1st stage filtering is applied.

PERFORMANCE ASSESMENT – Channels Ch0 to Ch2 were programmed to detect NH₃, HCN, and C₂H₂, respectively. A calibrated gas mixture of 10 ppmv±5% in N₂ (Matheson Tri-Gas) and a trace gas generator (Kin-Tek) with NH₃ and HCN permeation tubes were used to calibrate the QEPAS sensor responsivity and inter-channel crosstalk. All the measurements were performed with dry gases.

Responsivity and sensitivity calibration - Typical QEPAS scans acquired at 450 Torr for each of the three absorption lines from Table 1 are shown in Fig. 4.

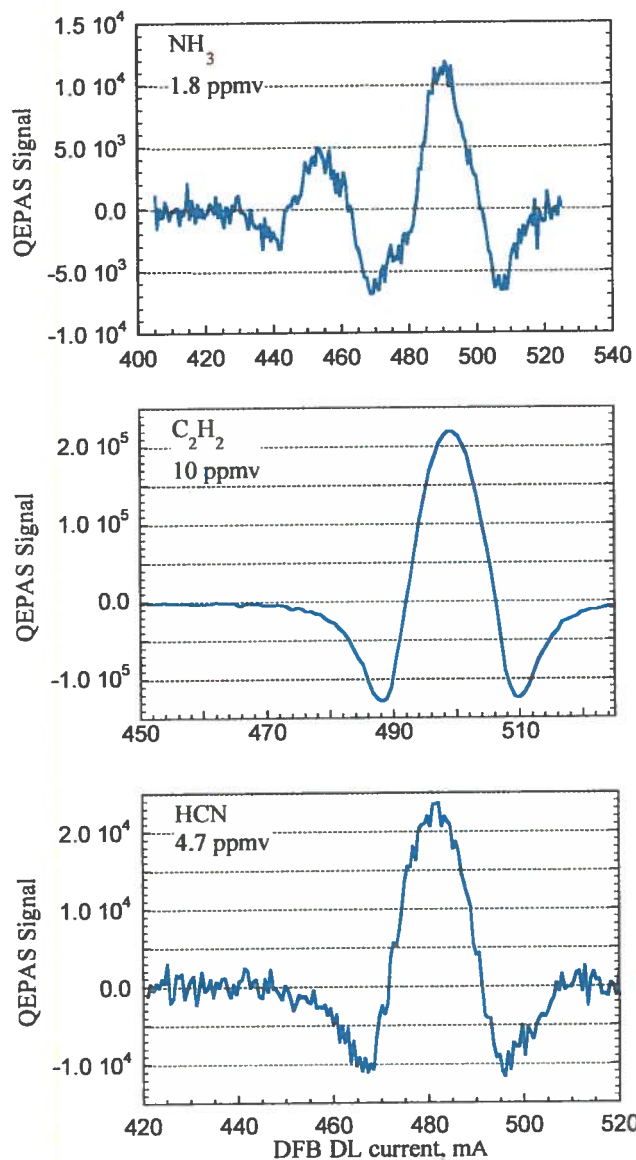

Figure 4: Spectral data acquired using DFB DL current scanning. The data acquisition time per point is 4s for NH₃ and 1s for C₂H₂ and HCN.

The amplitude of the DFB DL current modulation ensuring the highest QEPAS signal at 450 Torr gas pressure was found to be 24 mA for Ch0 and Ch1 and 18 mA for Ch2, which is determined by the spectral width of a selected absorption line. The vertical scale on Fig. 4 plots is in cnt units. Based on the peak line intensities and SNR for each of these plots and scaling to a 4s data acquisition time (averaging of 4 consecutive CEU outputs to RS232 port), we determine the responsivities and noise-equivalent (1σ) concentrations to be as shown in Table 2.

Table 2. QEPAS responsivity R and noise-equivalent concentration for 4s data acquisition time at 450 Torr

Molecule	R, cnt/ppmv	NEC (4s), ppbv
NH ₃	6.40×10^3	100
HCN	4.85×10^3	125
C ₂ H ₂	2.20×10^4	30

The ratio of $R(\text{NH}_3)/R(\text{C}_2\text{H}_2)$ is close to ratio of the corresponding absorption coefficients, while $R(\text{HCN})$ is lower than expected based on its absorption coefficient. This is presumably due to the less efficient V-T relaxation of this molecule in dry N₂, in agreement with our earlier studies [16].

Long-term integration limits – In order to determine the limits of SNR improvement with averaging time, the Ch2 data were collected during ~1 hour sampling clean air. An Allan variance analysis of these data was performed. The corresponding Allan variance plot is shown in Fig. 5.

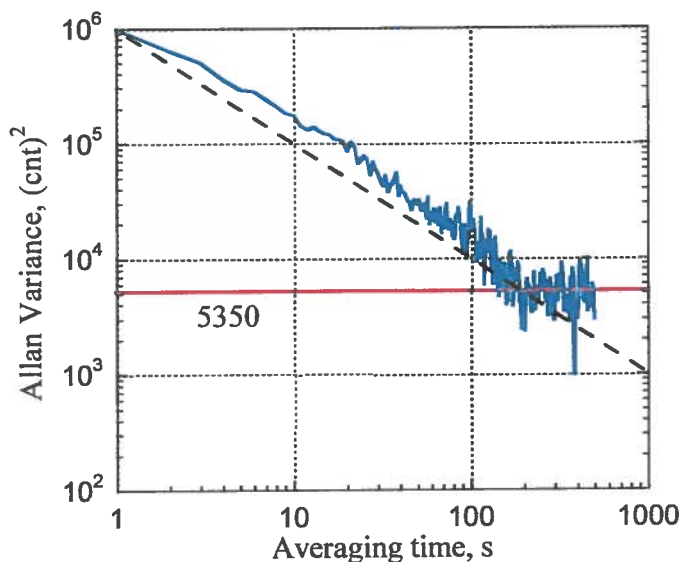

Figure 5: Allan variance for clean air data from Ch2. A minimum at 200s corresponds to ~75 cnt.

It can be seen that the Allan variance closely follows the white noise dependence (dashed line) down to 200s. Deviation for longer integration times can be caused by stray light in the spectrophone and drifting of the zero-levels in the electronics. However, this limitation is not

essential for most applications. The NEC for NH₃, HCN, and C₂H₂ is 12, 15, and 4 ppbv, respectively calculated based on the 75 cnt noise level with a 200 s integration time.

Cross-talk between the channels – Absorption lines of one of the three species from Table 1 can create non-zero signals at the set wavelength for another species. To take this effect into account we measured the relative input from each of the three target molecules into each of the measurement channels Ch0-Ch2. In particular, the C₂H₂ mixture was used as a diluent in the trace gas generator, thus resulting in gas containing both C₂H₂ and HCN or C₂H₂ and NH₃. An example of such a measurement is shown in Fig. 6.

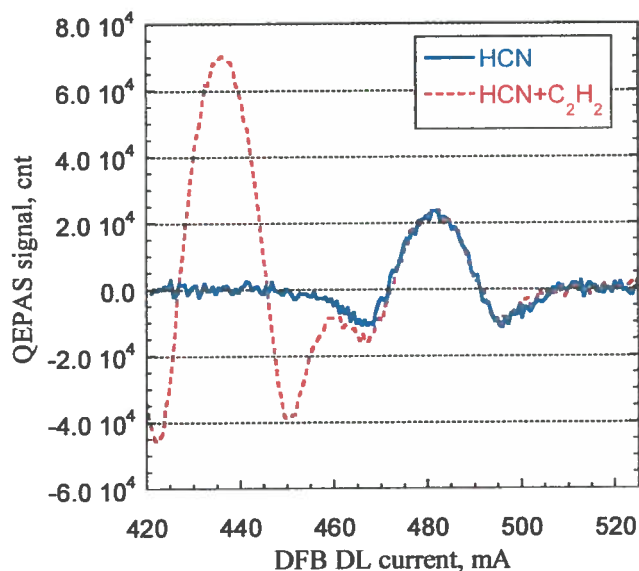

Figure 6: Spectral data acquired with 4.7 ppmv HCN in pure N₂ (solid line) and with an added 10 ppmv of C₂H₂. The C₂H₂ absorption does not interfere with the selected HCN line.

Table 3 presents a cross-talk matrix showing how strong a signal is generated by 1 ppmv of each species in each channel in terms of the channel's intended molecule concentration also expressed in ppmv. For example, 1 ppmv of NH₃ will induce a signal in Ch1 (HCN) equivalent to -0.045 ppmv HCN concentration.

Table 3. Cross-talk matrix.

Molecule	Ch0	Ch1	Ch2
NH ₃	1	-0.045	0
HCN	0	1	0
C ₂ H ₂	-0.037	0	1

CONCLUSIONS

The concept of using a single DFB DL for sensing of multiple trace gases was established. Only minor and easily accountable crosstalk was observed when detecting three species with overlapping absorption bands: NH₃, HCN, and C₂H₂. The QEPAS technique using a commercial NIR DFB DL as an excitation source proved capable of yielding the required <1ppmv sensitivity in <1 min integration time for each species.

Future work will focus on further refinements of both the spectrophone design and the electronics. In particular, the gas flow through the spectrophone module is planned to pass through the microresonator tubes, which will improve the ultimate time resolution of the sensor. We are also designing a CEU with a digital front end, which is expected to eliminate zero-level drifts, including temperature related effects.

Presently, NTT Electronics Corporation and Furukawa Electric Co. offer a multi diode laser array incorporating 12 DFB lasers and a SOA in a miniature package with a single-mode fiber output. Such a laser source covers the entire C-band or L-band and would allow to expand the range of simultaneously accessible chemical species. We consider incorporating such a diode laser source into a later upgrade of the QEPAS sensor.

ABBREVIATIONS

NIR	Near infrared
PAS	Photoacoustic spectroscopy
QEPAS	Quartz enhanced photoacoustic spectroscopy
DFB	Distributed feedback
DL	Diode laser
QTF	Quartz tuning fork
CEU	Control electronics unit
ENBW	Equivalent noise bandwidth
LCD	Liquid crystal display
ADC	Analog to digital converter
RMS	Root-mean-square
SNR	Signal to noise ratio
SOA	Semiconductor optical amplifier

ACKNOWLEDGMENTS

Financial support of the work reported was provided by the National Aeronautics and Space Administration via awards from the Jet Propulsion Laboratory, Pasadena, CA and Johnson Space Center, Houston, TX, the National Science Foundation via a sub-award from the Princeton University MIRTHERC, the Department of Energy via a sub-award from the Savannah River National Laboratory, Aiken, SC, and the Robert Welch Foundation.

REFERENCES

1. R. Claps, D. Leleux, F. V. Englich, F. K. Tittel, M. E. Webber, J. B. Jeffries, R. K. Hanson, J. C. Graf, and L. M. Vega, "Infrared Overtone Spectroscopy Measurements of Ammonia and Carbon Dioxide in the Effluent of a Biological Water Processor," *Proceedings: 31st Int'l Conf. on Environmental Systems (ICES)*, Orlando, FL (July 9-12, 2001).
2. A. Kosterev, G. Wysocki, Y. Bakhirkin, S. So, R. Lewicki, F. Tittel and R. F. Curl, "Application of quantum cascade lasers to trace gas analysis", M. Sigrist (Ed.) "Selected papers from the International Conference on Tunable Lasers and Fundamental Laser Spectroscopy", *Applied Physics B* **90**, 165-176 (2008)
3. F.K. Tittel, G. Wysocki, A. Kosterev and Y. Bakhirkin "Semiconductor laser based trace gas sensor technology: recent advances and applications" M. Ebrahizadeh and I. Sorokina (Eds), *Mid-Infrared Coherent Sources and Applications*, 467-493, Springer NATO Science Series (2008).
4. F. K. Tittel, Y. A. Bakhirkin, R. F. Curl, A. A. Kosterev, M. M. McCurdy, S. G. So and G. Wysocki, "Laser based chemical sensor technology: recent advances and applications", Y. J. Kim and U. Platt (Eds) "Advanced Environmental Monitoring XXII", Springer Verlag, Chapter 4, 50-63 (2008)
5. F.K.Tittel, Y.Bakhirkin, A.Kosterev, R.Lewicki, S.So, G.Wysocki and R.F.Curl, "Recent Advances and Applications of Mid-Infrared based Trace Gas Sensor Technology"-*Quantum Sensing and Nanophotonic Devices V*, Ed. R. Sudharsanan, C. Jelen, Proc. of SPIE, 6900, 69000Z-1 to -7 (2008).
6. J. S. Pilgrim, J. Kutzner and W. R. Wood, "High-performance optical contaminant monitor for spacecraft and habitats", *Proceedings of the 2007 Int. Conference on Environmental Systems*, Chigago, IL;. *Published by SAE as MS ICES 2007-01-3152*
7. A. A. Kosterev, Y. A. Bakhirkin, R. F. Curl, and F. K. Tittel, "Quartz-Enhanced Photoacoustic Spectroscopy", *Optics Letters* **27**, 1902-1904 (2002).
8. A.A. Kosterev, Y.A. Bakhirkin, F.K. Tittel, S. Blaser, Y. Bonetti, and L. Hvozdar, "Photoacoustic phase shift as a chemically selective spectroscopic parameter", *Applied Physics B, (Rapid Communications)* **78**, 673-676, (2004).

9. D. Weidmann, A.A. Kosterev, F.K. Tittel, N. Ryan, D. McDonald. "Application of widely electrically tunable diode laser to chemical gas sensing with quartz-enhanced photoacoustic spectroscopy", *Optics Letters* **29**, 1837-1839 (2004).
10. A. A. Kosterev and F.K. Tittel, "Ammonia detection by use of quartz-enhanced photoacoustic spectroscopy with a near-IR telecommunication diode laser", *Applied Optics*, **43**, 6213-6217 (2004).
11. J. Houston Miller, Andrew R. Awtry, Brendan McAndrew, Frank K. Tittel, Anatoliy A. Kosterev, Rui Q. Yang, Cory J. Hill, Chung M. Wong, Baohua Yang, and Greg Bearman, "Development of Optical Trace Gas Monitoring Technology for NASA Human Space Flight", Proceedings of the 2004 Int. Conference on Environmental Systems, Colorado Springs, CO (July 19-22, 2004). *Published by SAE as MS 2004- 01-2266*.
12. M. Horstjann, Y. A. Bakhirkin, A. A. Kosterev, R. F. Curl, and F. K. Tittel, "Formaldehyde sensor using interband cascade laser based quartz-enhanced photoacoustic spectroscopy", *Applied Physics B*, **79**, 799-803 (2004).
13. A. A. Kosterev, F. K. Tittel, D. Serebryakov, A. Malinovsky and I. Morozov, "Applications of Quartz Tuning Forks in Spectroscopic Gas Sensing.", *Rev. Sci. Instr.* **76**, 043105 (2005)
14. A. A. Kosterev, Y. A. Bakhirkin and F. K. Tittel, "Ultrasensitive gas detection by quartz-enhanced photoacoustic spectroscopy in the fundamental molecular absorption bands region" *Applied Physics B*, **80**, 133-138 (2005)
15. A. A. Kosterev, F.K. Tittel, D. V. Serebryakov, A. L. Malinovsky and I. V. Morozov, "Applications of Quartz Tuning Fork in Spectroscopic Gas Sensing", *Review of Scientific Instruments* **76**, 043105 (2005)
16. A. A. Kosterev, T. S. Mosely, and F. K. Tittel, "Impact of humidity on quartz enhanced photoacoustic spectroscopy based detection of HCN", *Applied Physics B* **85**, 295-300 (2006)
17. G. Wysocki, A. A. Kosterev, and F. K. Tittel "Influence of Molecular Relaxation Dynamics on Quartz-Enhanced Photoacoustic Detection of CO₂ at $\lambda = 2 \mu\text{m}$ ", *Applied Physics B* **85**, 301-306 (2006)
18. R. Lewicki, G. Wysocki, A. A. Kosterev, and F. K. Tittel, "CO₂ and NH₃ detection using distributed feedback diode laser at 2 μm with quartz-enhanced photoacoustic spectroscopy", *Applied Physics B* **87**, 157-162 (2007)
19. R. Lewicki, G. Wysocki, A. Kosterev and F.K. Tittel, "Quartz enhanced photoacoustic spectroscopy based detection of broadband absorbing molecules using a widely tunable, cw mid-infrared quantum cascade laser at 8.4 μm ", *Optics Express* **15**, 7357-7366 (2007)
20. A.K.Y. Ngai, S.T. Persijn, I.D. Lindsay, A.A. Kosterev, P. Gross, C.J. Lee, S.M. Cristescu, F.K. Tittel, K.J. Boller and F.J.M. Harren, "Continuous wave optical parametric oscillator for quartz-

enhanced photoacoustic trace gas sensing", *Applied Physics B* **89**, 123-128 (2007)

CONTACT

Dr. Anatoliy Kosterev is a Senior Faculty Fellow at the department of Electrical and Computer Engineering, Rice University. His background and scientific interests include applications of laser spectroscopy for molecular dynamics and ultra-sensitive chemical analysis. Dr. Kosterev can be contacted by email: akoster@rice.edu.